



# conveyor

TECHNOLOGY SERVICES

[www.conveyor-tec.com.au](http://www.conveyor-tec.com.au)

## Belt Maintenance Equipment Belt Cleaners

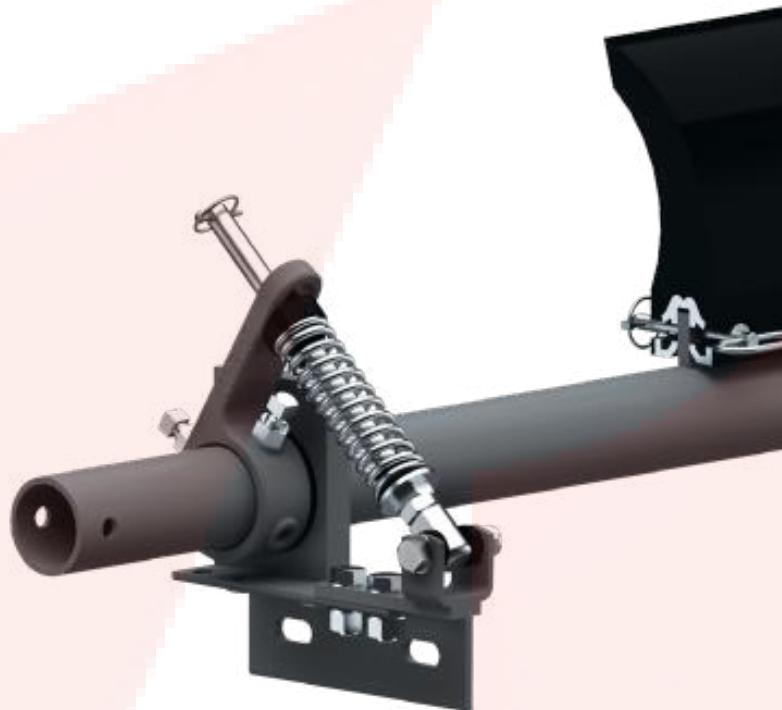

## Product Overview

## INTRODUCTION

# Belt Maintenance Equipment - Belt Cleaners

Installation of primary and secondary belt cleaners enhances the performance of any conveyor system.

- R Reducing the amount of carry back material
- R Reducing material spillage to minimize clean up work
- R Reducing the potential hazard of belt mis-tracking
- R Increase conveyor belt life
- R Increase production time due to excessive spillage
- R Protection against wearing components on the conveyor line

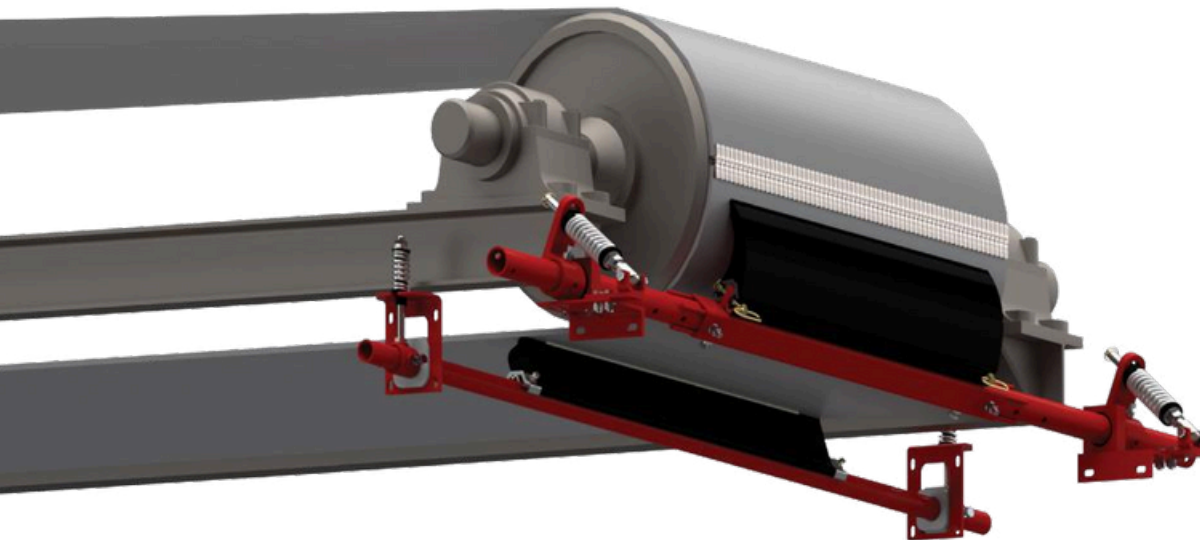

## Type of Belt Cleaners

### Primary Belt Cleaners

Tungsten Carbide for vulcanised conveyor systems  
Polyurethane for conveyor systems with mechanical fasteners  
Mounted on the head pulley of the conveyor system below the centre line out of the material flow for protection  
Removes the bulk of material flow from the conveyor

### Secondary Belt Cleaners

Tungsten Carbide for vulcanised conveyor systems  
Specialised Tungsten Carbide for conveyor systems with mechanical fasteners  
Mounted directly behind where the conveyor belt leaves the head pulley  
Removes the sticky fine or wet material for when Primary Cleaners cannot be installed on the head pulley  
Multiple secondary cleaners to be fitted on extreme applications

PRODUCT OVERVIEW

# Primary Cleaners



MDP - MATO Drop-on Primary Cleaner



MTP - MATO T-Slot Primary Cleaner



MCP1 - Tungsten Carbide Cleaner

# Secondary Cleaners



MUS2 - Tungsten Carbide



MUS3 - Tungsten Carbide



MUS3 - Polyurethane



MCS2 - Tungsten Carbide



MCS3 - Tungsten Carbide



MCS4 - Tungsten Carbide



MCS5 - Tungsten Carbide

PRIMARY BELT CLEANERS

# MDP - MATO Drop-on Primary Cleaner

- 1 piece full width Polyurethane (PU) blade option
- Quick and easy installation

The MDP - MATO Drop-on Primary Cleaner is the simplest primary cleaner available on the market, with its easy tension spring application for constant tensioning and reduced adjustability.

Quick and easy blade replacement by removing the blade locking pin is simple. The MDP range of Polyurethane Primary Cleaners are manufactured with a unique self-lubricating blade to reduce friction and blade wear.



Above image shown with CS1 End Assembly.



MATO have an optional plate style end assembly (CS2) available for special applications, please contact your MATO representative to discuss additional details as these are available upon request.

## MDP Technical Specifications

Tension Methods: CS - Compression Spring.



	MDP120	MDP185	MDP235	MDP235HD	MDP306HD
Blade Material Blade	PU 120mm up to	PU 185mm up to	PU 235mm up to	PU 235mm up to	PU 306mm up to
Height Belt Speed	3.5m/s 150mm -	3.5m/s 250mm -	5.0m/s 400mm -	5.0m/s 400mm -	7.5m/s 500mm -
Head Pulley Diameters	500mm Yes Yes	900mm Yes Yes	1000mm Yes Yes	1000mm Yes Yes	2100mm Yes Yes
Mechanical Fasteners					
Reversing Belts					

## PRIMARY BELT CLEANERS

# MTP - MATO T-Slot Primary Cleaner

R Individual 150mm Polyurethane (PU) blade option

The MTP replacement blades are supplied in 150mm lengths and have an easy slide on slide off application.

The MTP P2 PU blade has MATO's unique self lubricated additive to prevent friction and blade wear.



## MTP Technical Specifications

Tension Methods: CS - Compression Spring.



	MTP185 PU	MTP235 PU
Blade Material Blade	185mm up to	235mm up to
Height Belt Speed	3.5m/s 250mm -	5.0m/s 400mm -
Head Pulley Diameters	900mm Yes Yes	1000mm Yes Yes
Mechanical Fasteners		
Reversing Belts		

PRIMARY BELT CLEANERS

# MCP1 - Tungsten Carbide Cleaner

Individual Tungsten Carbide (TC) Blade

MATO standard MCP1 blade/ cushion arrangement.

2 blade options are available and 4 different arm sizes to suit multiple pulley diameters



## MCP1 Technical Specifications

Tension Methods: Bolt Tensioning

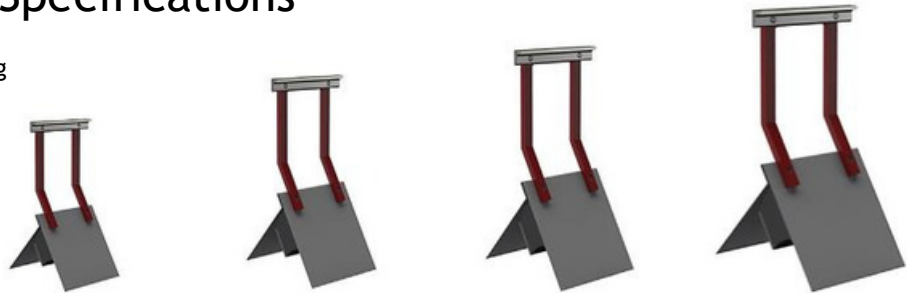

	MCP1-SS	MCP1-S	MCP1-M	MCP1-L
Blade Material Blade	TC 200mm	TC 200mm	TC 200mm	TC 200mm
Widths Blade Height	120mm up to	185mm up to	235mm up to	306mm up to
Belt Speed Head Pulley	5.0m/s 250mm -	5.0m/s 500mm -	5.0m/s 800mm -	5.0m/s 1000 -
Diameters Mechanical	500mm No Yes	800mm No Yes	1000mm No Yes	1500mm No
Fasteners Reversing				Yes
Belts				

## SECONDARY BELT CLEANERS

# MUS2 - Tungsten Carbide

M-Trak segmented Blade Cleaners

Slide on and off system for quick and easy installation

The MUS2 secondary cleaner is unique within itself to have a parallelogram designed into the cushion allowing constant blade angle attacking to the material flow, this allows for automatic adjustability within the cleaner for when the belt thickness can vary.

The MUS2 is well suited for conveyor belts with mechanical fasteners when the (TI) tungsten impact blade is applied.

For Vulcanised belt MATO recommend the (TL) tungsten long-life blade.



# MUS3 - Tungsten Carbide

M-Trak segmented Blade Cleaners

Slide on and off system for quick and easy installation

The MUS3 cleaner is designed to fit in small and restricted conveyor areas where limited space is available. With its low profile it is an excellent option for a tungsten carbide secondary belt cleaner.

The MUS3 is also designed for reversing conveyor belts such as feeder belts or belts which have roll back.

Suitable for conveyors with mechanical belt fasteners.



## SECONDARY BELT CLEANERS

# MUS3 - Polyurethane

M-Trak segmented Blade Cleaners

Slide on and off system for quick and easy installation

The MUS3 Polyurethane cleaner is a versatile cleaner, can be used as a water wiper or an alternative cleaner within any full system to enhance removal of any remaining material.



## MU Technical Specifications

Tension Methods: CS - Compression Spring or AB - Air Bag Tension. Cushion for the MUS2 and MUS3 are available in 45 and 65 duro hardness for optimum belts speeds. The MUS3 PU blade has a hardness of 93a.



	MUS2	MUS3	MUS3
Blade Material Blade	TC - Tungsten Carbide	TC - Tungsten Carbide	PU - Polyurethane
Increments Belt	150mm up to 5.0m/s	150mm up to 5.0m/s	150mm up to
Speed For Reversing	No Yes	Yes Yes	3.5m/s Yes Yes
Belts Mechanical			
Fasteners			

## SECONDARY BELT CLEANERS

# MCS2 - Tungsten Carbide

The MCS2 secondary cleaner is an excellent option to reduce the amount of carry back returned down the conveyor line.

The MCS2 allows for individual blade movement as each blade/cushion is individually mounted. Can be used as a stand alone cleaner, or for improved performance add in a pre cleaner on the head pulley.

The MCS2 is suitable for vulcanised belts only. There are 2 blade options available (TI) Tungsten Impact blade for harsh conditions, or the (TL) Tungsten Long-life blade where belt conditions are ideal.



---

# MCS3 - Tungsten Carbide

The MCS3 secondary cleaner is an excellent option to reduce the amount of carry back returned down the conveyor line.

The MCS3 allows for individual blade movement as each blade/cushion is individually mounted. Can be used as a stand alone cleaner, or for improved performance add in a pre cleaner on the head pulley.

The MCS3 cleaner is suitable for conveyor belts with mechanical fasteners. In addition the MCS3 is used for reversing / feeder conveyors.

2 blade options are available (TI) Tungsten Impact blade for mechanical fasteners or (TL) Tungsten Long-life blade where belt conditions are ideal.



## SECONDARY BELT CLEANERS

# MCS4 - Tungsten Carbide

The MCS4 secondary cleaner is an excellent option to reduce the amount of carry back returned down the conveyor line.

The MCS4 allows for individual blade movement as each blade/cushion is individually mounted. Can be used as a stand alone cleaner, or for improved performance add in a pre cleaner on the head pulley.

The MCS4 is suitable for conveyors with mechanical fasteners.



---

# MCS5 - Tungsten Carbide

Heavy Duty MCS5 secondary cleaner is an excellent option to reduce the amount of carry back returned down the conveyor line. The MCS5 arrangement has a special hardened steel heat treated blade to withstand abrasion, impact and durability.

The MCS5 allows for individual blade movement as each blade/cushion is individually mounted.

Can be used as a stand alone cleaner or for improved performance add in a pre cleaner on the head pulley.

The MCS5 is suitable for conveyors with mechanical fasteners.



## SECONDARY BELT CLEANERS

### MCS Technical Specifications

The MCS range of bolt-on secondary cleaners for customers who currently use equivalent products.



	MCS2	MCS3	MCS4	MCS5 TC - Tungsten
Blade Material	TC - Tungsten Carbide	TC - Tungsten Carbide	TC - Tungsten Carbide	Carbide 150mm up to
Increments Belt	150mm up to 5.0m/s	150mm up to 5.0m/s	150mm up to 5.0m/s	5.0m/s Yes Yes
Speed For Reversing	No	Yes	No	Yes
Belts Mechanical				
Fasteners				



# conveyor

TECHNOLOGY SERVICES

[www.conveyor-tec.com.au](http://www.conveyor-tec.com.au)

[www.conveyor-tec.com.au](http://www.conveyor-tec.com.au)